

**WallWalker, LLC**  
145 South 720 West  
Lehi, Utah 84043

Place  
Stamp  
Here

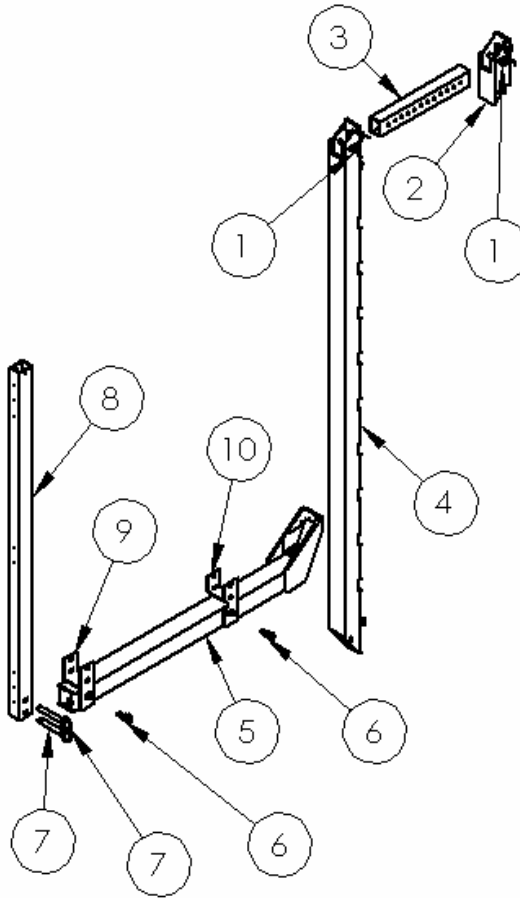

#### WallWalker® Parts List

1. Tab Lock Pin
2. Slider Bracket
3. Slider Tube
4. Vertical Beam
5. Horizontal Beam
6. Thumb Screw
7. Detent Pin
8. Handrail Post
9. Plank Bracket
10. Notched Plank Bracket

To order parts call toll free  
**(877) 844-9255**

**WallWalker™**  
BRAND PORTABLE SCAFFOLD

## Warranty Registration

Mail Today



**Detach & Mail Promptly**

# WallWalker™

BRAND PORTABLE SCAFFOLD

## LIMITED WARRANTY

WallWalker™ makes every effort to assure that its products meet high quality and durability standards, and warrants to the original purchaser that this product is free from defects in materials and workmanship for the period of 1 year from the date of purchase. This warranty does not apply to damage due directly or indirectly to misuse, abuse, negligence or accidents; or to lack of maintenance. We shall in no event be liable for death, injuries to persons or property, or for incidental, contingent, special, or consequential damages arising from the use of our product. Some states do not allow the exclusion or limitation of incidental or consequential damages, so the above limitation of exclusion may not apply to you.

To take advantage of this warranty, the product or part must be returned to us with transportation charges prepaid. Proof of purchase and an explanation of the complaint must accompany the merchandise. If our inspection verifies the defect, we will either repair or replace the product at our election or we may elect to refund the purchase price if we cannot readily and quickly provide you with a replacement. We will return repaired products at our expense, but if we determine there is no defect, or that the defect resulted from causes not within the scope of the warranty, then you must bear the cost of returning the product.

This warranty gives you specific legal rights and you may also have other rights which vary from state to state.

### IMPORTANT NOTICE TO PURCHASERS

Please be sure you and your employees are familiar with the product safety labels attached to the WallWalker™.

If instruction label becomes damaged or otherwise unreadable, contact WallWalker LLC for a free replacement.

The user of this product should be familiar with all local, state & federal codes and standards that may apply to the selection, use and care of planking and scaffold components.

These products meet or exceed current OSHA standards

## Congratulations!

You have joined many satisfied users who have purchased one of the most versatile scaffold products produced today. The WallWalker™ fits any wall with standard or accessory parts, and can be hung on the inside or outside wall, beam, or other structural member. Our quick release pin makes wall width adjustments fast and easy. The WallWalker™ can also accommodate several different height settings by sliding the support arm up and down the vertical beam with our unique climber. The support arm extends over 38". The WallWalker™ is constructed of lightweight structural aluminum.

DUTY RATED 500 LBS / PAIR

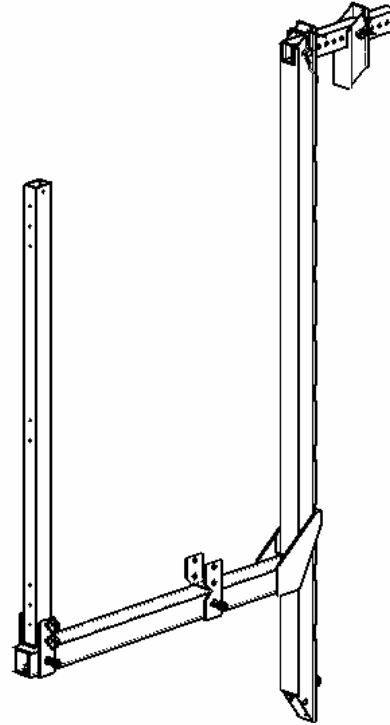

145 South 720 West • Lehi, Utah 84043  
877-844-9255 Toll Free

[www.wallwalker.com](http://www.wallwalker.com)

**PLEASE MAIL THIS WARRANTY  
CARD WITHIN 30 DAYS OF  
PURCHASE**

I heard about the WallWalker™ from:

- Mail
- Dealer
- Friend
- Advertisements / Magazine
- Salesman
- Other

WallWalker™ was purchased from:

- WallWalker, LLC
- Dealer
- Other

YES  NO

have previously purchased a WallWalker™

How many sets of WallWalker™ purchased this time? \_\_\_\_\_

understand and agree that if I mail this card within thirty (30) days of purchase, I am entitled to the benefits of the limited warranty, a copy of which I have retained. I also confirm that I have read and understand the instructions and warning labels.

Name \_\_\_\_\_ Company Name \_\_\_\_\_

Address \_\_\_\_\_ (Street & Number)  
\_\_\_\_\_  
\_\_\_\_\_  
(City, State, Zip)

Date \_\_\_\_\_ Signature \_\_\_\_\_